

**OH 245-800 kV Knee-type disconnect**

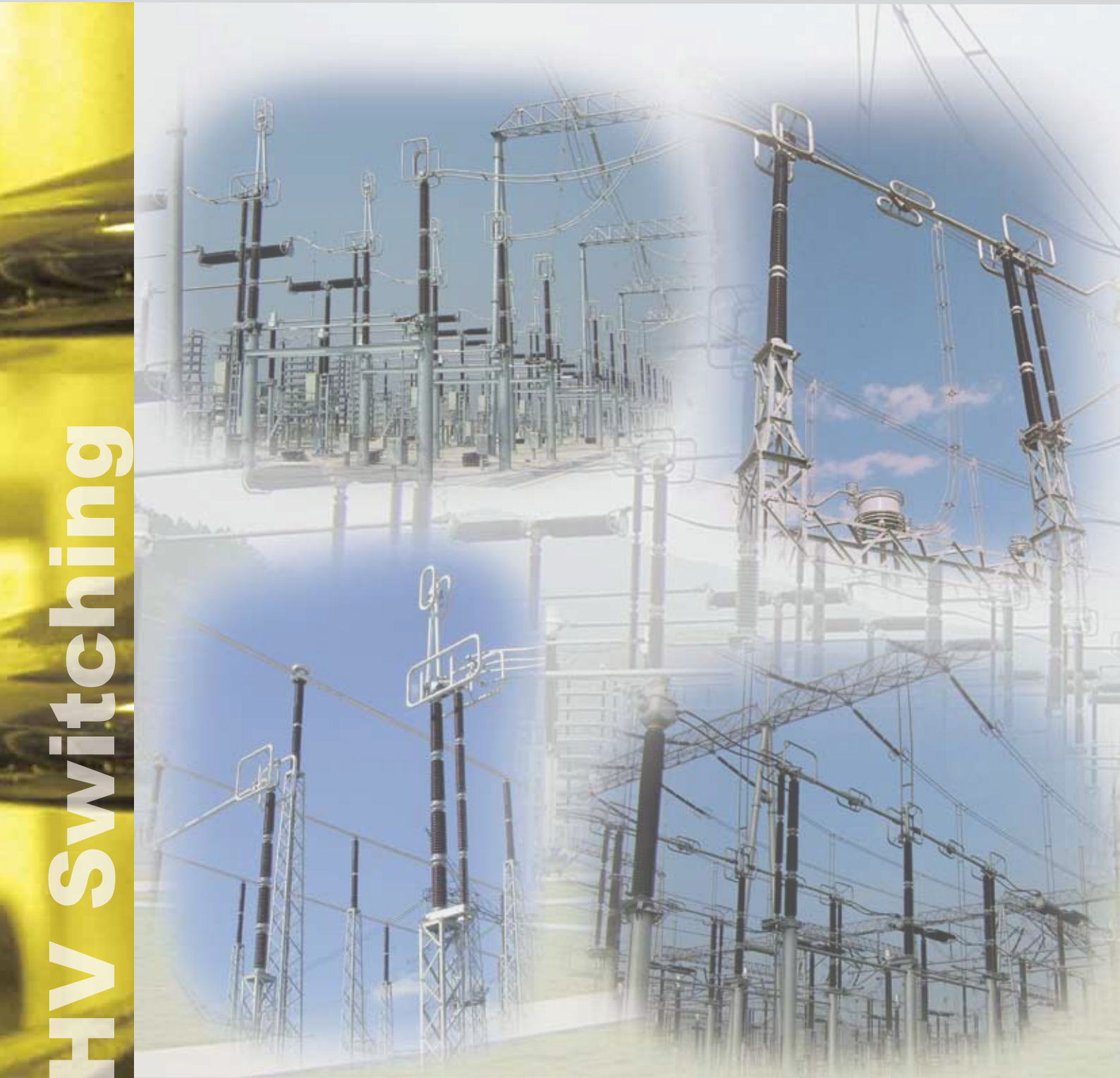

**HV Switching**

## We know how

Our range of knee-type disconnectors is designed to ensure the best performances and reliability, which are the result of our 60-year old experience. Over 100,000 disconnectors installed in more than 100 countries worldwide are the guarantee of best-buys.

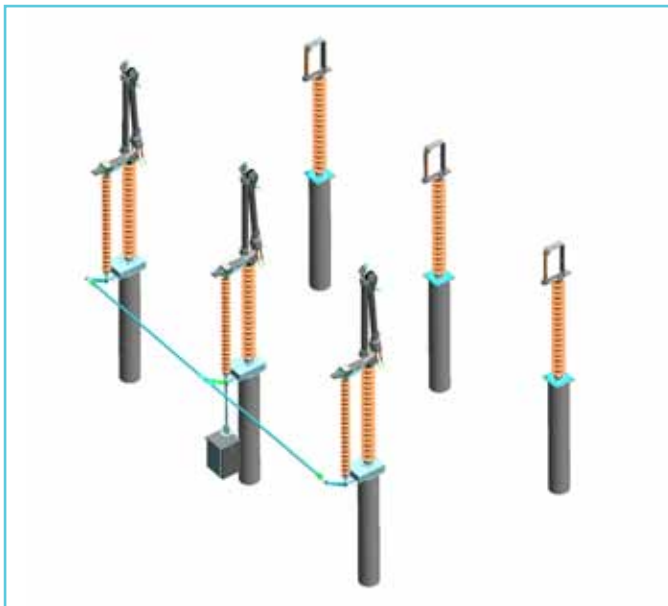

## The OH knee-type disconnector

The OH disconnector is composed of three poles operated simultaneously either by a single operating mechanism and mechanical linkages between the poles, or by one single operating mechanism for each pole.

Since the arm moves on a vertical plane, the knee-type disconnector allows to minimize the phase-to-phase distance, thus allowing space saving in substation design; furthermore, if compared to the traditional vertical-break type, its reduced vertical dimension when in open position makes it less exposed to wind effects and seismic loads, as well as a better solution for substations with busbars passing over disconnectors.

Special configurations of OH are also available; among them, in particular, the “double OH”, which allows for compact substations to be designed.

The reliability of the OH is ensured by the physical separation of the mechanical and the electrical functions.

When short-time current flows through it, the electro-dynamic forces increase the contact pressure of fingers on the fixed contact bar.

The insulating columns used for the OH comply

### Double OH

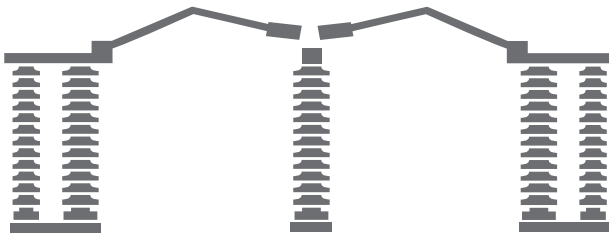

with the IEC or the ANSI Standards. Special heights and creepage distances are also available upon request.

Like all our models, the OH complies with the latest international standards (IEC, ANSI), but can also be customised according to customers' particular specifications.

## Earthing switch

Integrated earthing blades are available for mounting on each pole, with the same short-time current withstand capability.

The earthing switch is actuated by the same types of operating mechanisms as the disconnector, either manually or electrically, either single- or 3-pole. It can be electrically and/or mechanically interlocked with the main switch.

## Construction features

The arm of each pole is made of hard-drawn aluminium tubes, with silver-plated copper fingers bolted at the end (jaw).

According to the rated voltage, the current path at hinged points is ensured by copper braids or by self-cleaning, maintenance-free rotary contacts, with silver-plated “fingers”, individually loaded by stainless steel springs.

The arm, ideally balanced (by a spring housed inside its first half) to ensure a smooth low energy demanding motion, is supported by an aluminium alloy frame, which includes one HV terminal.

The fixed contact consists of a silver-plated copper tube, bolted to an aluminium alloy support, which includes the other HV terminal.

All the exposed hardware of the main circuit is made of stainless steel.

Where necessary, suitable shields protect the main circuit from the corona effect.

The base-frame consists of two separate elements, made of hot-dip galvanized steel, one supporting the moving arm and the other the fixed contact.

The bearings are sealed and guaranteed to ensure maintenance-free operation for the whole life of the equipment.

The whole design and manufacturing process is ruled by ISO 9001 certified procedures, to guarantee a perfect reproducibility of performances from type-testing to the series production.



## Operating principle

The base-frame supports the two post insulators on which the moving arm and the fixed contact are bolted. The rotating insulating rod (driving insulator), which operates the arm, is directly connected with the operating mechanism.

From the open position, the insulating rod **1** rotates, to transmit the movement to the first half-arm **2** through a bevel gear and a crank-rod system. The second half-arm **3** movement is controlled by a rack-pinion system housed inside the knee. Both half-arms move together till closing the jaw at their end **4**; the closing of the jaw, controlled by a rod inside the second half-arm, only occurs in the last phase of the operation, thus ensuring that the disconnector “catches” the fixed contact **5** for certain.

After reaching the final closed position, the moving arm is locked by the passing of a dead-point, preventing any accidental opening.

The flat HV terminals **6** are shown in the next page figure; customised terminals are also available upon request.

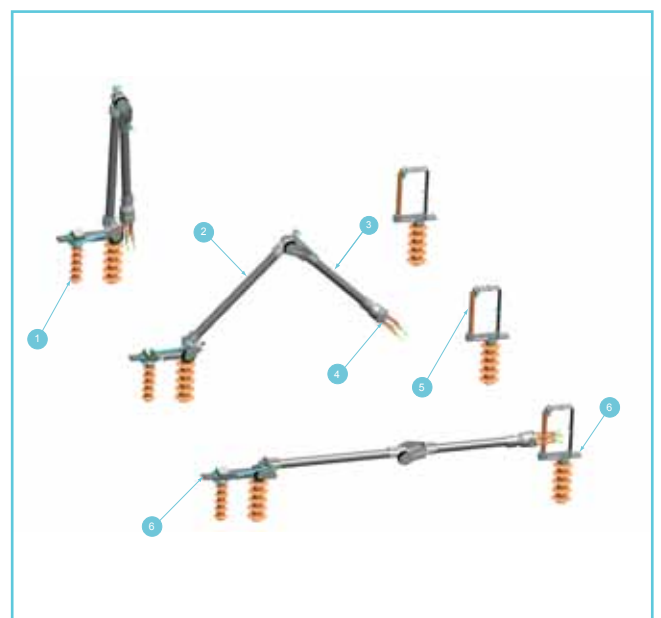

## Ratings and dimensions

The values in the table refer to IEC standards, unless explicit reference to ANSI is made; for missing ANSI ratings, refer to C37.32

Rated voltage		$U_r$ (kV)	245	300	362	420	550	800
Rated power-frequency withstand voltage	TE	$U_d$ (kV)	460	380	450	520	620	830
	AID	$U_d$ (kV)	530	435	520	610	800	1150
Rated lightning impulse withstand voltage	TE	$U_p$ (kV <sub>p</sub> )	1050 (IEC) 1050 (ANSI)	1050 (IEC) -	1175 (IEC) -	1425 (IEC) 1300 (ANSI)	1550 (IEC) 1800 (ANSI)	2100 (IEC) 2050 (ANSI)
	AID	$U_p$ (kV <sub>p</sub> )	1200	1050(+170)	1175 (+205)	1425 (+240)	1550 (+315)	2100 (+455)
Rated switching impulse withstand voltage	TE	$U_s$ (kV <sub>p</sub> )	-	850	950	1050	1175	1550
	AID	$U_s$ (kV <sub>p</sub> )	-	700 (+245)	800 (+295)	900 (+34 5)	900 (+450)	1175 (+650)
TE: To Earth AID : Across the Isolating Distance								
Rated continuous current		$I_r$ (A)	up to 6300 IEC/ANSI (depending on rated voltage)					
Rated short-time withstand current		$I_k$ (kA)	up to 75 / 3s (depending on rated current)					
Rated peak withstand current		$I_p$ (kA <sub>p</sub> )	up to 195 (depending on rated current)					
Dimensions (mm)		A	4600	5470	5470	5830	6540	7575
B	IEC		3150	3420	4020	4510	4810	6350
	ANSI		3187	-	-	4259	5021	5749
C	IEC		4610	5010	5610	6277	6940	9115
	ANSI		4647	-	-	6026	7151	8514
D			750	890	890	890	890	1040
E1	IEC		2515	2535	3135	3625	3925	5500
	ANSI		2552	-	-	3374	4136	4899
E2	IEC		2505	2345	2945	3435	3735	5345
	ANSI		2542	-	-	3184	3946	4744
F			3320	4190	4190	4550	5260	5980
G			930	860	860	860	860	1115
L			180	320	320	320	320	320
M			230	330	330	330	330	330
K			18 L 40	20 L 40	20 L 40	20 L 40	20 L 40	20 L 40
R	IEC		2300	2300	2900	3350	3650	5300
	ANSI		2337	-	-	3099	3861	4699

## Reliability and maintenance

Due to lifetime greased or self-lubricated hinges and to self-wiping contacts, the maintenance of OH metallic parts is ensured by their own motion.

The use of corrosion-free (or coated) materials for all components ensures an exceptional reliability over many years of service.

The mechanical endurance performance exceeds the IEC standard requirements.

## Optional devices

Upon request, the disconnector can be equipped with a bus-transfer current switching device compliant with IEC 62271-102 (Annex B).

The integrated earthing switch can also be fitted with optional induced current switching devices compliant with IEC 62271-102 (Annex C).

For operation under severe ice conditions (up to 20 mm), ice shields are available for protection of the equipment (where needed).

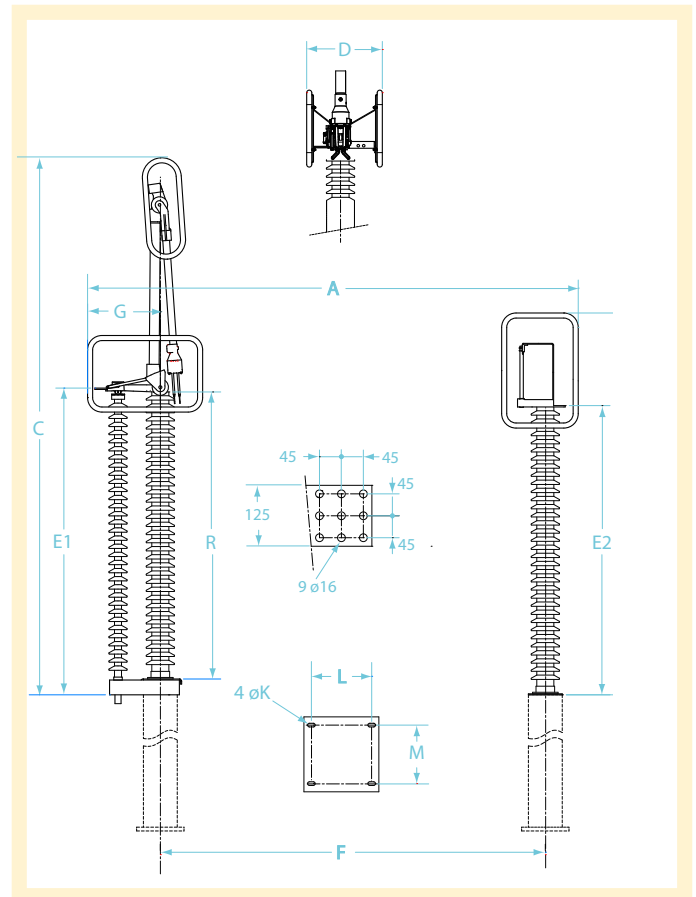

### COELME

Via G. Galilei, 1/2 - 30036 Santa Maria di Sala (VE) - Italia  
Tel.: +39 041 486022 - Fax: +39 041 486909  
E-Mail: [contact@coelme-egic.com](mailto:contact@coelme-egic.com), [www.coelme-egic.com](http://www.coelme-egic.com)

### EGIC

60b, rue L. et R. Desgrand - 69625 Villeurbanne CEDEX - France  
Tel.: +33 4 72 66 20 70 - Fax: +33 4 72 39 08 65  
E-Mail: [contact@coelme-egic.com](mailto:contact@coelme-egic.com), [www.coelme-egic.com](http://www.coelme-egic.com)