

CM Manual operating mechanisms



HV Switching

The versatility of CM mechanisms allows for easy adaptation to Customers' specific requirements.

We know how

Our range of manual operating mechanisms is designed to ensure the best performances and reliability, which are the result of our 60-year old experience.

Over 100,000 disconnectors and switchers installed in more than 100 countries worldwide and operated by our mechanisms are the guarantee of best-buys.



Optional and safety

CM operating mechanisms are designed for the manual operation of medium and high voltage outdoor disconnectors and earthing switches.

On the top side of the mechanisms, there are the rotating disks, pre-arranged for the connection to the vertical driving shafts by means of U-bolts.

For the operation of disconnectors or earthing switches, the special lever has to be inserted in the seat on the disk and the vertical shaft rotated (every mechanism is provided with a lever).

The shape of the rotating disks allows for the mechanical interlocking between the disconnector and the earthing switch, if present (CM202). This mechanical interlock ensures that the motion of the shafts is possible only in safe conditions.

Moreover, the disks are equipped with a device for locking the equipment in the open and closed positions (by means of a padlock).

Reliability and maintenance

- The housing is made of aluminium alloy, to prevent corrosion, and guarantees a high protection degree (IP 44, or higher upon request).
- An anti-condensation heater prevents harmful moisture condensation inside the cabinet.
- The external components are either made of aluminium alloy or hot dip galvanized or stainless steel.

For the best dependability on site to be ensured, the CM has undergone the most severe test conditions:

- extra low temperatures down to - 50° C
- heavy wetting
- extended mechanical endurance (exceeding the IEC standard requirements)

Design and construction

The CM mechanisms are manufactured in the standard types CM102 and CM202, for the operation of disconnectors without and with integrated earthing switch respectively.

CM mechanisms consist of an upper support, made of an aluminium alloy casting, and of a lower case containing the electrical components.

Disconnectors can be operated by one operating mechanism through driving shafts and rods (Fig 1: three-pole configuration) or by one operating mechanism per pole (Fig 2: single-pole configuration).

The signalling of equipment position is given through auxiliary switches which can be of the "normally open" (NO) or "normally closed" (NC) type.

To make the installation at site easier, the case is provided with a wide front cover, fastened by screws, and an adjustable coupling with the vertical shafts.

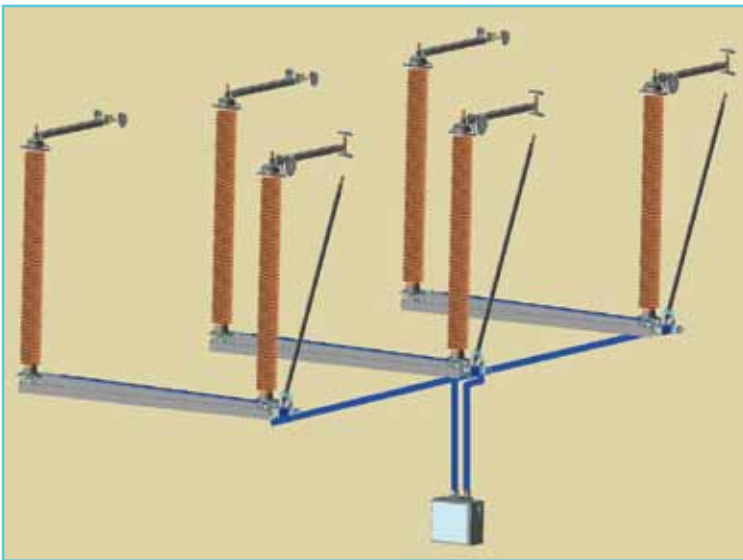

Fig. 1

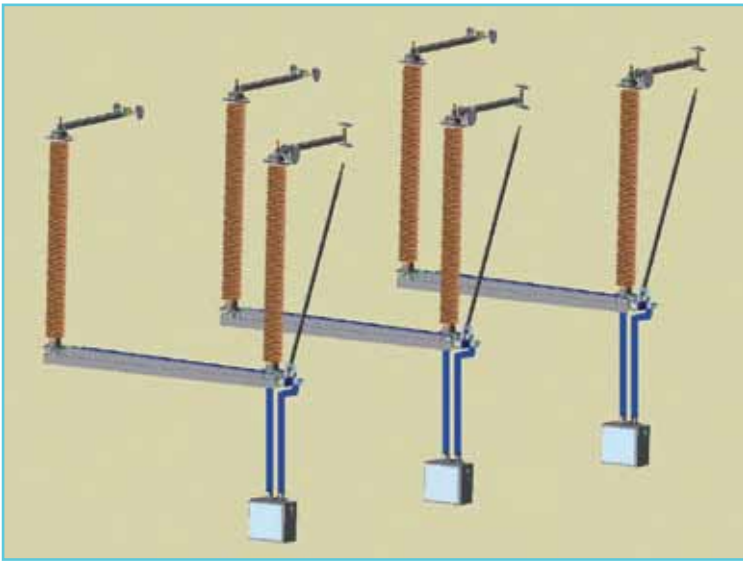
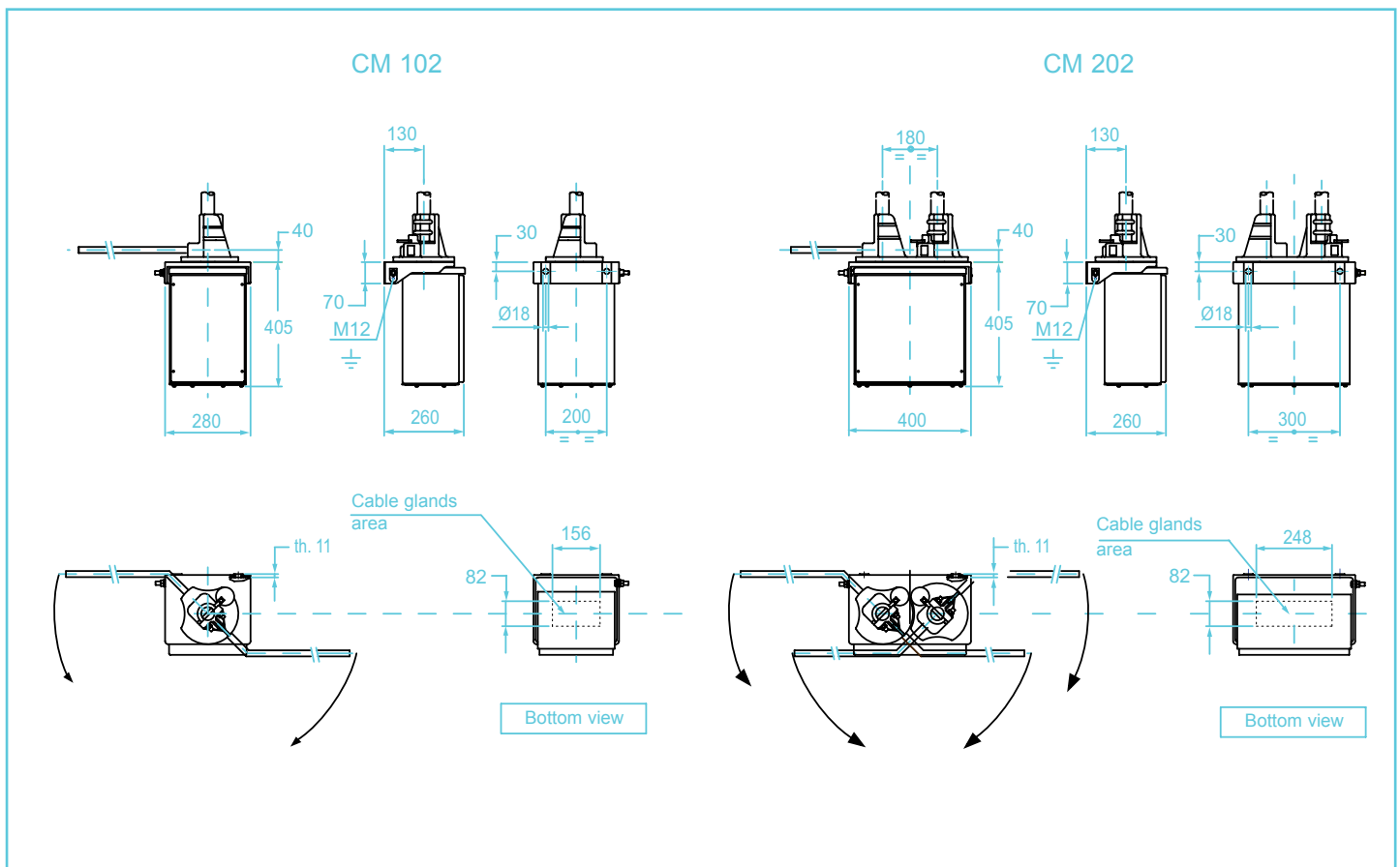

Fig. 2



Technical data

	CM102	CM202
Disconnecting switch	Manual	Manual
Earthing switch	NA	Manual
Weight	10 kg	20 kg
Operating angle	180°	
Anti-condensation heater		
- rated power	10 W	
- rated voltage	230 V	
Auxiliary switches		
- rated current	10 A	
- breaking capacity (as per IEC 62271-1)	10 A (250 V _{ac}) 2 A (220 V _{dc})	
- standard quantity:		
DS	4 NO + 4 NC	
ES	4 NO + 4 NC	

Electrical diagram legend

RA	Anti-condensation resistance
RR	Heater
T	Thermostat
IAR	Mini CB
IAP	Mini CB
PR	Electrical socket
L	Internal Lamp
I	Mini CB
PSS	Release pushbutton of ESS
ESS	Electromagnetic interlocking device (DS)
PST	Release pushbutton of EST
EST	Electromagnetic interlocking device (ES)
A-B	Auxiliary switches (DS)
C-D	Auxiliary switches (ES)

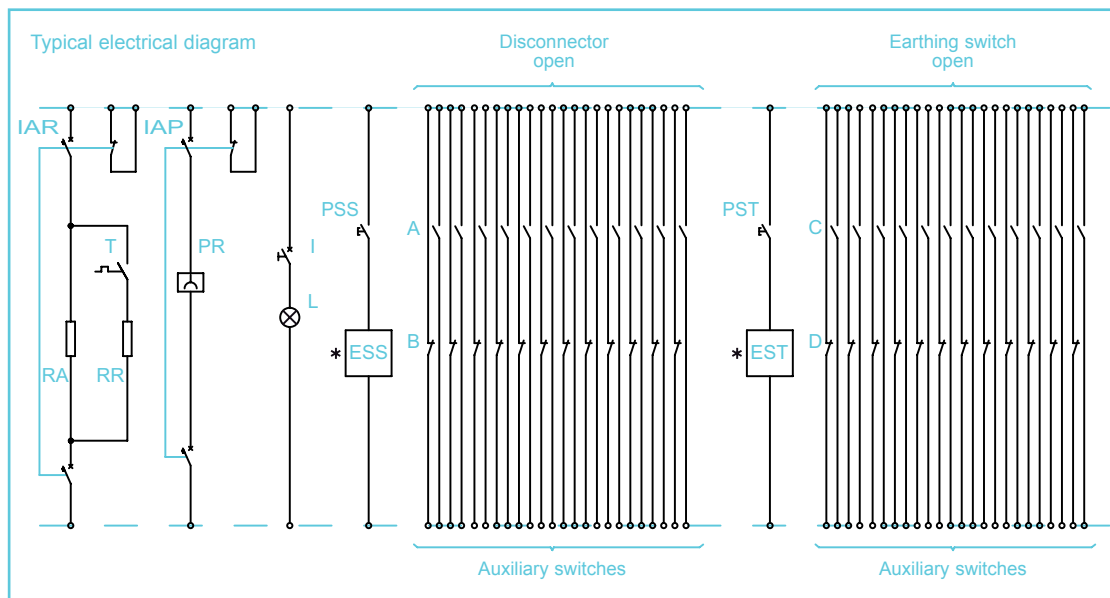

* Manual operation of disconnecter (or earthing switch) is possible only when ESS (or EST) is energized.

Optional features

Upon request, the mechanism can be equipped with the following accessories:

- electromagnetic interlocking device
- internal lamps
- heater with thermostatic control
- protection of heaters by mini CB
- electrical socket
- additional auxiliary switches
- provision for key interlocks
- key-lock of the housing door
- ...



COELME

Via G. Galilei, 1/2 - 30036 Santa Maria di Sala (VE) - Italia
Tel.: +39 041 486022 - Fax: +39 041 486909
E-Mail: contact@coelme-egic.com, www.coelme-egic.com

EGIC

60b, rue L. et R. Desgrand - 69625 Villeurbanne CEDEX - France
Tel.: +33 4 72 66 20 70 - Fax: +33 4 72 39 08 65
E-Mail: contact@coelme-egic.com, www.coelme-egic.com